

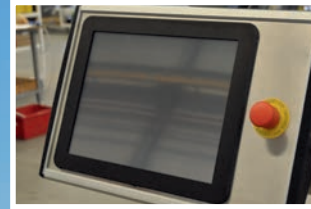

# Manter<sup>®</sup>

*weighing and packaging equipment*

## M12 V



 - Weger uitgevoerd met 12 V-vormige weegschalen die naar 2 zijden openen.

- Lage val, het gewicht wordt direct op de afvoerband gestort.

- Optimaal voor hoge snelheid kleine gewichten.

- Verschillende afvoersystemen mogelijk, te combineren met alle verpakkingsmachines.

- Bediening door middel van gebruiksvriendelijk touchscreen

 - Waage ausgeführt mit V-model Wiegebehälter die nach 2 Seiten öffnen.

- Niedrigen fall, das Gewicht wird direct auf den Abtransportband geladen.

- Optimal für hohe kapazität mit kleine gewichte.

- Verschiedene Abtransportsysteme sind möglich, zu kombinieren mit allen Arten Verpacker.

- Zu bedienen mit Touchscreen.

 - Weigher equipped with 12 V-shaped weighing buckets opening to 2 sides.

- Low drop, the weight will be dumped directly onto the discharge belt.

- Optimized for high capacity with small weights.

- Different discharge systems possible, to combine with all kinds of packing systems.

User friendly touchscreen.



*All in weighing and packaging solutions*

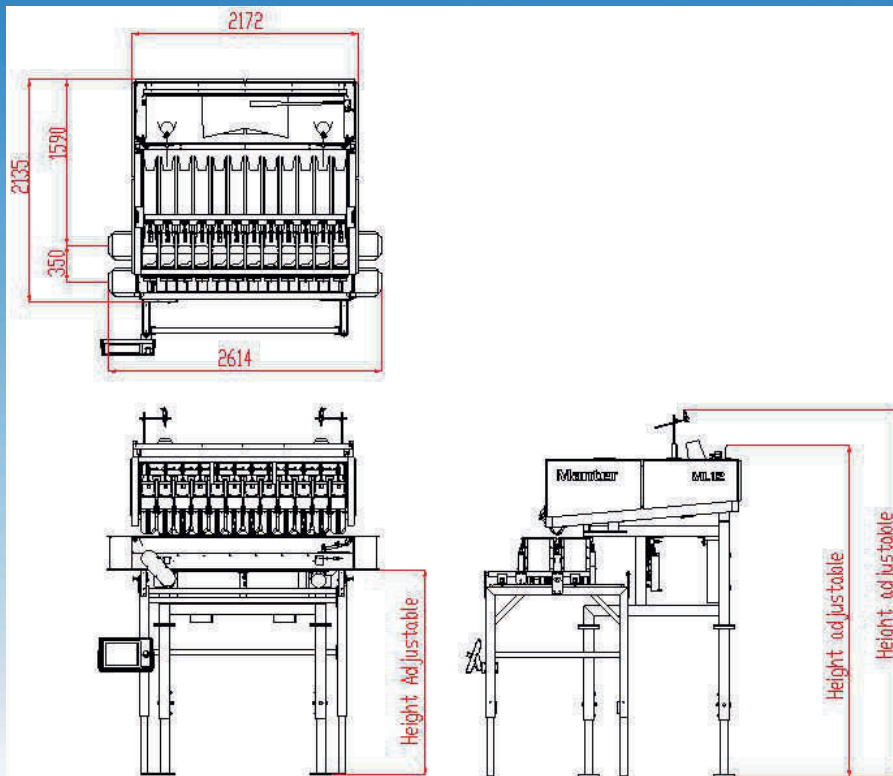

 Specificaties:

Weegbereik:  
Capaciteit bij 1kg tot:  
Luchtverbruik  
(geconditioneerde droge lucht):  
Stroomvoorziening:  
Vermogen:  
Gewicht Machine:

 Spezifikationen:

Bereich max.:  
Leistung mit 1kg bis zu:  
Luft Verbrauch  
(konditionierte trockene Luft):  
Spannungsdaten:  
Anschlusswert:  
Gewicht der Maschine:

 Specifications:

Weighing range:  
Capacity at 1kg up to:  
Air consumption  
(conditioned dry air):  
Supply Voltage:  
Power consumption:  
Weight of the machine:

250 gr. - 7,5 kg<sup>1</sup>  
60 pcs/min<sup>2</sup>  
6 Bar - 150 L/min  
3x400V/50Hz+N+GND  
4,6 kW  
1450kg

- 1/2: Afhankelijk van gewicht en afvoersysteem. - Abhängig von der Gewicht und Abtransportsystem. -  
- Depending on weight and discharge system. -



Manter International bv  
Phileas Foggstraat 66  
7825 AL Emmen - Holland  
tel: +31 591 626300  
e-mail: sales@manter.com

**www.manter.com**