



Bandit 10-GB www.trio-b.com KRAMP101-027 0210 All product definitions, technical information and specifications are subject to correction.



Krampe is not only a manufacturer of tandem and tridem trailers but an innovator and creator of designs. Behind each Krampe tipper lies more than 20 years of engineering. Even our early models were manufactured to such high standard that many of them are still in operation today. If you require further information, don't hesitate to contact us or one of our dealers. We will be pleased to offer advice!

Krampe GmbH Agricultural engineering and construction

Flamschen 62, D-48653 Coesfeld
Tel.: +49 (0) 25 41 / 80 178-0
Fax: +49 (0) 25 41 / 80 178-14
E-Mail: info@krampe.de
Internet: www.krampe.de

Your dealer will be pleased to offer advice!

Bandit

Conveyor Belt Trailer



Innovation is a tradition at Krampe.

Since 1982 trailers have been produced at Coesfeld in the region of Münster. Since that time many ideas and innovations of Krampe have consistently set new standards and helped to promote the standard of high-quality engineering "Made in Germany". The conveyor belt wagon "Bandit" represents an entirely new concept. We had to create something new in order to remedy the disadvantages of push-off trailers and those of body tippers.



A tipper cannot unload in a building of low ceiling height. A push-off trailer can indeed unload, but much space is lost due to the large volume tailgate. Furthermore the construction of a push-off trailer is more complex compared to the tippers. Due to its higher empty weight, the push-off trailer has a reduced payload. When using a body tipper, it can lead to stability problems on slope or unstable grounds. When using a very long trailer, caution is recommended during tipping.

Krampe sets a complete new course with the conveyor belt wagon. By means of this novel trailer suitable for year-round use, nearly all agricultural products can be transported. The conveyor concept is also suitable for applications in excess of 10m or more. To tell you the truth, the personnel of Krampe were surprised themselves by the excellent functioning of the "conveyor wagon". Simply ingenious – ingeniously simple.

During the Agritechnica 2009 the "Bandit" was awarded with the prestigious DLG Silver medal.

The idea of the conveyor belt trailer is as simple as ingenious, and holds many advantages for you as a customer compared to the push-off trailers: a considerably higher payload due to a reduced empty weight, simple operation combined with the ability to easily discharge the load in the required doses.



The conveyor belt wagon Bandit is equipped with the same tailgate as the body tippers of the Big Body product line. It is not a volume tailgate needed to extend the load platform, and also not a tailgate which reaches to the sky in opened position. The Bandit can open its solid-constructed tailgate also in low buildings. The unloading of all types of loads is made easier.

Following the motto "why make it complicated, if it can be simple?", our engineers have equipped the body floor of the Bandit with a hard-wearing roller conveyor. The load, which lies on the conveyor belt, is moved out. So the trailer can be discharged at different places in the right doses. The driver has the full control.

The conveyor belt is driven by means of two hydraulic motors. Only a flow volume of 60 to 100 l/min (at 175 bar) is necessary. Compared to the push-off trailers, a major advantage is that no oil is required from the traction head. A small oil volume does the job.

The Bandit is mounted on wide tyres. On demand the Bandit can be equipped with caster steering or forced steering axles, with pneumatic or hydraulic suspension, with Tandem or Tridem chassis (like the Bandit 980). With a complete axle load of 10t per axle, thanks to the axle base of 1,81 m. What you need at last is payload.

Flexible charge and discharge in right doses.



Sealing lips on the lateral sidewalls make sure that no transported good penetrates in the conveyor belt guiding device.



Powerful hydraulic motors at the front and at the rear walls roll the conveyor belt forwards or backwards, depending on the loading process.



The standard remote control possesses not only a manual function, but also an automatic one, in order to facilitate repeated operating sequences (i.e. repeated loading or unloading).



Also high density bulk materials (such as sand, lime, pebbles or compost), can be loaded or unloaded without any problems.

During the last years, Krampe has again and again developed niche products and brought them to production standards. Also many innovative details (e.g. such as the hydraulic tailgate equipped with self-adjusting hooks) are in the meantime standards in the construction of agricultural vehicles.

Once again the brilliant engineers of Krampe break new ground with the conveyor belt wagon. The Bandit is equipped with a rubber floor movable in two directions. The load can easily be loaded or unloaded without using a tipping hydraulic system. Two hydraulic motors located at the front and back walls, drive the rubber conveyor belt forwards or backwards. The load on the belt will either be loaded or unloaded respectively.

The new trailer concept offers many advantages:

- Reduced empty weight of approx. 1,2 to 1,9t.
- Reduced oil requirement compared to the push-off trailers as only two hydraulic engines must be driven. The necessary oil flow requirement amounts only to 60 to 100l/min (at 175 bar). The high-volume oil requirement of the push-off trailers does not apply.
- The load can be unloaded in the right doses thanks to the continuous adjustable speed of the conveyor. An especially important advantage for the loading of e.g. potatoes or beets.
- The conveyor can also be used for loading. The loading of rectangular bales or heavy goods can be carried out from the rear, without any problems. By means of the standard remote control, the feed motion of the conveyor can easily be operated (e.g. from another, loading tractor).
- In spite of the big loading volume the Bandit can be also unloaded in low buildings as it has no extended volume tailgate. The volume tailgate is state of the art technology, for all push-off trailers, but during loading or unloading it requires a greater height due to its large construction.
- Thanks to the "real inspection window" you are always able to view inside the body.
- The conveyor belt is also constructed for the transport of heavy goods, such as sand. Adhesive goods such as sewage sludge or lime can completely be conveyed off. This is an important advantage compared to a silage wagon.
- Simply to clean as there are only a few movable components.



With an eye for the detail.

Thanks to its high-quality chassis the Bandit has good performance on rough terrain. Parabolic springs with dynamic axle-levelling are standard specification.



It is child's play to load: by means of the remote control, the direction of the conveyor can easily be operated from the tractor.



In addition to caster steering axles, we also offer forced steering axles. When reversing, these axles remain exactly in the track. During travel at speed or on sloping terrain, the Bandit does not fishtail. Safety on the road is increased, and the wheels and chassis are preserved.



Alternatively we offer a chassis with an hydraulic suspension providing an excellent stability, especially for vehicles with a high centre of gravity and a tight centre of spring. Benefit from our long-lived experience in the construction of high-quality chassis. We will show you the ropes!



In much of Germany a tarpaulin is obligatory. We offer different systems from the simple roll-up tarp to the luxurious sliding canopy as on trucks.



As optional extra, a pneumatic suspension can be delivered, which enables a stable and exceptionally convenient drivability. The high range of spring enables a good cross-country mobility and reduces the draft requirement. No axle sinks in the ground as the load is distributed equally on each axle.

Technical data	Tandem		Tridem
	Bandit 650	Bandit 750	Bandit 980
Model			
Permissible total weight *	22,000 kg at 40 km/h	24,000 kg at 40 km/h	34,000 kg at 40 km/h
Empty weight **	approx. 6,900 to 7,800 kg	approx. 7,400 to 8,200 kg	approx. 9,200 to 10,200 kg
Payload acc. to German law	approx. 15,000 kg	approx. 16,600 kg	24,800 kg
Technical payload	approx. 20,000 kg	approx. 22,000 kg	approx. 28,000 kg
Permissible tongue load	4,000 kg	4,000 kg	4,000 kg
Hitch height	approx. 65 cm	approx. 65 cm	approx. 65 cm
Draft requirement	from 102 kW (140 PS)	from 132 kW (180 PS)	from 140 kW (190 PS)
Required oil hydraulic engines	Recommended 100 litres at 175 bar / Load Sensing	Recommended 100 litres at 175 bar / Load Sensing	Recommended 100 litres at 175 bar / Load Sensing
Type of brakes	Compressed-air / ALB-valve	Compressed-air / ALB-valve	Compressed-air / ALB-valve
Track width of steering type axle	2.15 m	2.15 m	2.15 m
Interior dimensions of body	6.50 x 2.32 x 1.52 m	7.50 x 2.32 x 1.52 m	9.80 x 2.32 x 1.52 m
Transport capacity without silage extension ***	23.0 m ³	26.5 m ³	34.4 m ³
Transport capacity with 60 cm silage extension ***	31.7 m ³	36.6 m ³	47.6 m ³
Transport capacity with 80 cm silage extension ***	34.7 m ³	40.0 m ³	52.0 m ³
Platform height unloaded	1.65 m	1.65 m	1.65 m
Overall length	8.71 m	9.71 m	12.00 m

* Permissible total weight of 24 t or 34 t resp. In Germany only with an axle base of 1,81 m.

** Empty weight and payload depend on the respective equipment.

*** All body volumes were determined using the water capacities and not, like other forage wagons, after having pressed or piled the forage.

Tyre Table

Manufacturer	Dimensions	Ply PR	Possible engraving	Type	Height in mm	max. width	Load Index	max. load rating t / per axle	At speed	Permissible max. speed
Michelin	600/ 55 R 26.5	-	Cargo X Bib	neu	1,348	626	165 D	14 t / 10.3 t mit 4.0 bar	40 / 65 km/h	65 km/h
Michelin	710/ 50 R 26.5	-	Cargo X Bib	neu	1,382	728	170 D	16.3 t / 12 t mit 4.0 bar	40 / 65 km/h	65 km/h
Michelin	710/ 50 R 30.5	-	Cargo X Bib	neu	1,495	728	173 D	17.6 t / 13 t mit 4.0 bar	40 / 65 km/h	65 km/h
Alliance	650/ 55 R 26.5	-	390	neu	1,395	660	170 D	16.3 t / 12 t mit 4.0 bar	40 / 65 km/h	65 km/h
Alliance	800/ 45 R 26.5	-	390	neu	1,390	810	177 D	19.9 t / 14.6 t mit 4.0 bar	40 / 65 km/h	65 km/h

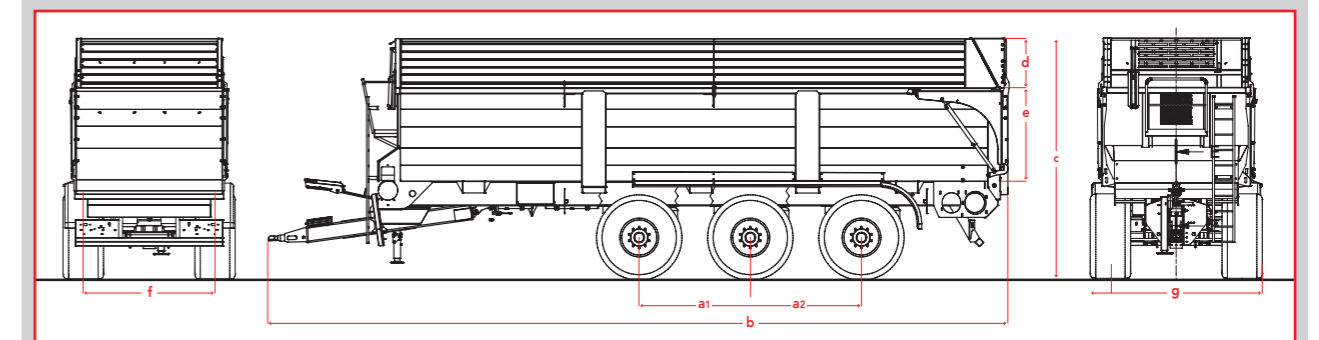

Tyre dimensions	650/ 55 R 22.6	650/ 55 R 26.5	710/ 50 R 26.5
	Bandit 650	Bandit 750	Bandit 980
a1 / a2 Wheelbase	1.55 or 1.81 m	1.55 or 1.80 m	1.55 or 1.81 m
b Length from centre pin to rear gate	8.65 m	9.65 m	11.94 m
c Overall height	3.97 m	3.97 m	3.97 m
d Extension of sidewalls	0.80 m	0.80 m	0.80 m
e Height of rear door	1.52 m	1.52 m	1.52 m
f Gauge	2.15 m	2.15 m	2.15 m
g Width up to outer edge of mud guard	2.81 m	2.81 m	2.81 m